



LAWNTON

Medizintechnik

Parametrium-Scheren und -Klemmen ...

Parametrium Scissors and Forceps ...

Tijeras y pinzas parametrium ...

Ciseaux et pinces-clamps à ligaments larges ...

Forbici e pinze Parametrium ...



... zur vaginalen und abdominalen Hysterektomie

... for vaginal and abdominal hysterectomy

... para histerectomía vaginal y abdominal

... pour hystérectomie vaginale et abdominale

... per l'isteretomia vaginale e addominale



DURACUT® Parametriumscheren

DURACUT® Parametrium Scissors

DURACUT® Tijeras Parametrium

DURACUT® Ciseaux à ligaments larges

DURACUT® Forbici Parametrium



05-1650 22,5 cm, 9"
05-1690 26,5 cm, 10 1/2"
05-1693 30,5 cm, 12"
05-1696 35,5 cm, 14"

05-1651 22,0 cm, 8 3/4"
05-1691 26,0 cm, 10 1/4"
05-1694 30,0 cm, 12"
05-1697 35,0 cm, 13 3/4"

05-1652 21,5 cm, 8 1/2"
05-1692 25,5 cm, 10"
05-1695 29,5 cm, 11 3/4"
05-1698 34,5 cm, 13 1/2"

Die Parametriumscheren gewährleisten einen sauberen Schnitt des Bindegewebes seitlich der Gebärmutter. Sie sind in ihrer Form und Biegung den Parametriumklemmen angepasst!

The parametrium scissors guarantee a perfect cut of the tissue lateral to the uterus. The form and bend is relevant to the parametrium forceps.

Las tijeras parametrium garantizan un corte mejorable del tejido conjuntiva lateral del útero. Las tijeras son adecuada a las pinzas parametrium con respecto a su forma y curvatura.

Les ciseaux à ligaments larges garantissent une coupe nette du tissu conjonctif latéral de l'utéro. Elles sont adaptées dans leurs formes et courbures aux pinces-clamps pour ligaments larges!

Le forbici Parametrium consentono un taglio netto del tessuto connettivo laterale dell'utero. Grazie alla loro forma e curvatura si adattano alle pinze Parametrium.

ATRAUMATIC-GRIP Parametriumklemmen

ATRAUMATIC-GRIP Parametrium Forceps
 ATRAUMATIC-GRIP Pinzas parametrium
 ATRAUMATIC-GRIP Pincès-clamps pour ligaments larges
 ATRAUMATIC-GRIP Pinze Parametrium

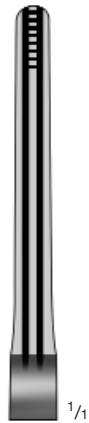

96-0540
22,0 cm, 8³/₄"



96-0541
21,5 cm, 8¹/₂"



96-0542
21,0 cm, 8¹/₄"



96-0543
20,5 cm, 8"

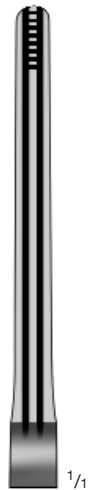
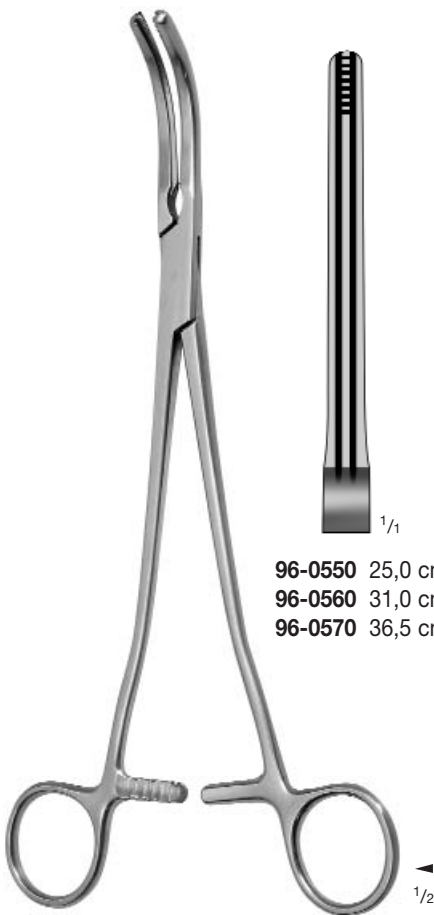

96-0550 25,0 cm, 10"
96-0560 31,0 cm, 12¹/₄"
96-0570 36,5 cm, 14¹/₄"



96-0551 24,5 cm, 9³/₄"
96-0561 30,5 cm, 12"
96-0571 36,0 cm, 14¹/₄"



96-0552 24,0 cm, 9¹/₂"
96-0562 30,0 cm, 12"
96-0572 35,5 cm, 14"



96-0553 23,5 cm, 9¹/₄"
96-0563 29,5 cm, 11³/₄"
96-0573 35,0 cm, 13³/₄"

Durch die atraumatische Längsriefung und den feinen Zähnnchen am distalen Ende der Maulteile garantieren die Parametriumklemmen einen festen Halt des Gebärmutter-Bindegewebes.

The parametrium forceps assure a strong grip of the uterine tissue in consequence of the atraumatic longitudinal serration of the jaws.

Las pinzas parametrium garantizan a través de la acanaladura longitudinal atraumática y los dientes muy fino al "fin distal" de la boca una consistencia estable del tejido conjuntiva del útero.

Les pincès-clamps pour ligaments larges garantissent une tenue ferme du tissu conjonctif de l'utérus grâce à la striure longitudinale atraumatique et grâce aux dents fines de la partie distale des mors.

Grazie alla scanalatura longitudinale e i dentini delicati nella parte distale del morso, le pinze Parametrium garantiscono una presa sicura del tessuto connettivo dell'utero.

Ihr Fachhändler:
Your distributor:
Su distribuidor:
Votre distributeur:
Il Vs. distributore è:

LAWTON

Medizintechnik

LAWTON GmbH & Co. KG

Württembergischer Str. 23

D-78567 Fridingen/Germany

Postfach 45

D-78565 Fridingen/Germany

Telefon: (07463) 99 65-0

Telefax: (07463) 99 65-20

e-mail: info@lawton.de

<http://www.lawton.de>

05.03. • No. 03/80 • Printed in Germany • Copyright by Lawton GmbH & Co. KG

Technische Änderungen vorbehalten. We reserve the right to make alternations. Cambios técnicos reservados. Sous réserve de modifications techniques. Ci riserviamo il diritto di modifiche tecniche.